

- (i) The internal measurements of a tin of baked beans are:
- radius 3.6 cm,
 - height 9.3 cm.



- (b) A mathematically similar tin of baked beans has a radius of 4.2 cm.



Diagram not drawn to scale

Calculate the height of the larger tin of beans.

[2]

Higher Numeracy Nov 2016 P2 Q1b

The Headteacher decides to place signs around the school site to stop pupils using their bikes on grassed areas.

He introduces a new sign to pupils in the school newsletter.
The size of the sign in the newsletter is shown below.

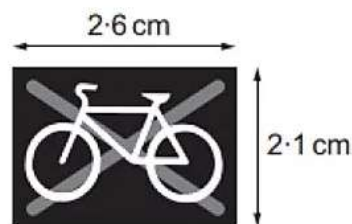

Diagram not drawn to scale

A mathematically similar new sign is placed near the side of the playing field.



Diagram not drawn to scale

It is 33.6 cm high.
How wide is this sign?

[2]

Yared is going to make a door wedge.

- (a) The cross-section of the wedge is shown below.
The horizontal length is 12 cm and the vertical height is 3 cm.

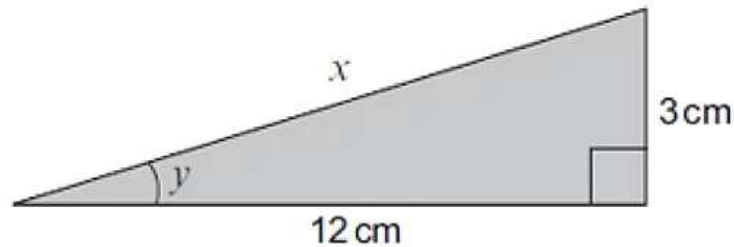

Diagram not drawn to scale

- (b) Yared decides to make a larger wedge that is mathematically **similar** to the one shown in part (a).
This wedge is to have a vertical height of 4.5 cm.

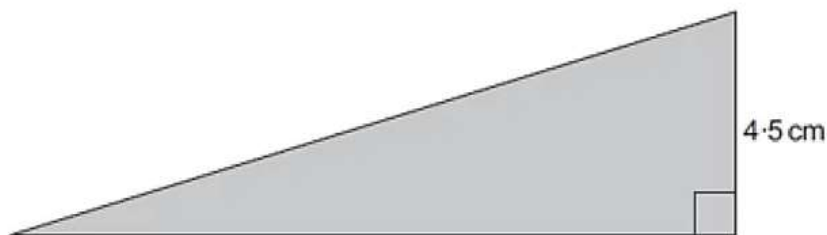

Diagram not drawn to scale

Calculate the horizontal length of this door wedge. [2]

Higher Numeracy Nov 2018 P1 Q4c

Jade needs a new passport photograph.
A passport photograph must be 45 mm high by 35 mm wide.

Jade has a mathematically similar photograph that she could reduce in size to use as her new passport photograph.

The height of this photograph is 9 cm.
Calculate the width of this photograph. [2]

The picture shows a mountain hut.
The hut

- stands on a rectangular base,
- has a uniform cross-section.



(a) Draw a sketch of the plan view of the mountain hut.

[1]

(b) This mountain hut is shown on a map.
The scale of the map is 1 : 50 000.
On the map the mountain hut is 4.2 cm from a farmhouse.
How far away is the hut from the farmhouse?
Give your answer in km.

[3]

Higher Maths Summer 2018 P2 Q7

The diagrams below show two similar shapes, $ABCD$ and $PQRS$.

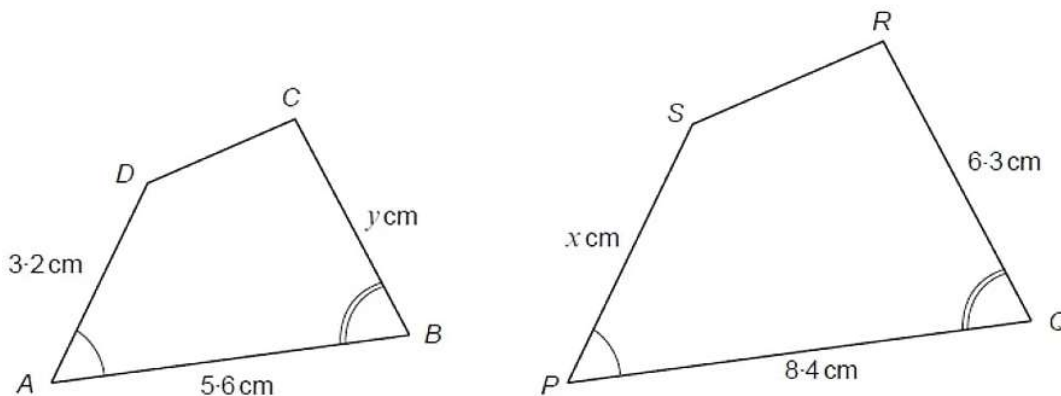

Diagrams not drawn to scale

(a) Calculate the value of x .

[2]

(b) Calculate the value of y .

[2]

(c) Explain clearly why the following statement cannot be true.

[2]

'The length of CD is 3.9 cm and the length of RS is 6.5 cm'.

- (a) *You will be assessed on the quality of your organisation, communication and accuracy in writing in this part of the question.*

A company uses its logo in every part of its business.

The smallest version, used on letterheads, has a perimeter of 9 cm and an area of 5 cm².

The largest similar version, used on their delivery vans, has a perimeter of 2.7 metres.

Painting the logo on the delivery vans costs £200 per m².

How much it would cost to paint one logo on the side of a van?

You must show all your working.

[7]

Higher Numeracy Nov 2019 P1 Q7

Mr Aston lives at 137 Ffordd Uchel.

He is ordering some new signs for his house and for his gatepost from a website.



Diagram not drawn to scale

All the signs available on the website are **mathematically similar**.

He selects a rectangular sign for the front of his house.

It has a length of 42 cm and a height of 24 cm.

The digits 1, 3 and 7 on the sign are all 18 cm high.

The rectangular sign Mr Aston is considering for his gatepost has a height of 20 cm.

- (a) Calculate the height of the digits 1, 3 and 7 on the sign Mr Aston is considering for his gatepost. [2]

Height of the digits 1, 3 and 7 is cm

A company produces two **similar** road signs.

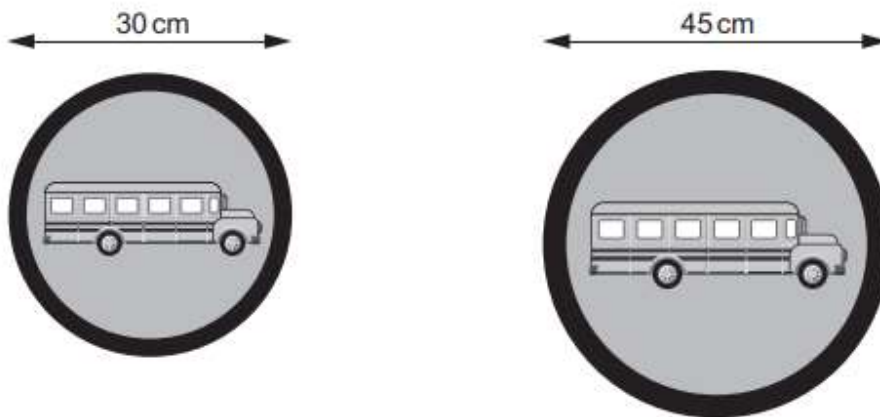

Diagrams not drawn to scale

- (a) The cost of the paint needed for the smaller road sign is £1.60.
Calculate the cost of the paint needed for the larger sign.

[4]

Higher Numeracy Nov 2019 P2 Q9

A company makes Welsh flags in mathematically similar sizes.
Two of their similar flags are shown.

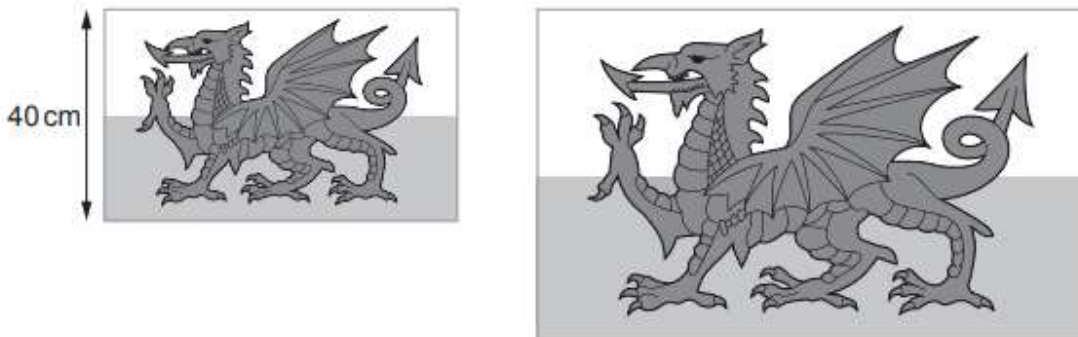

Diagrams not drawn to scale

The area of the larger flag is 96% greater than the area of the smaller flag.
The height of the smaller flag is 40 cm.

Calculate the height of the larger flag.

[4]

Higher Numeracy Summer 2019 P2 Q8b

A company makes buckets in two sizes. Both sizes are in the shape of a frustum of a cone. Bucket A has the dimensions shown in the diagram below.

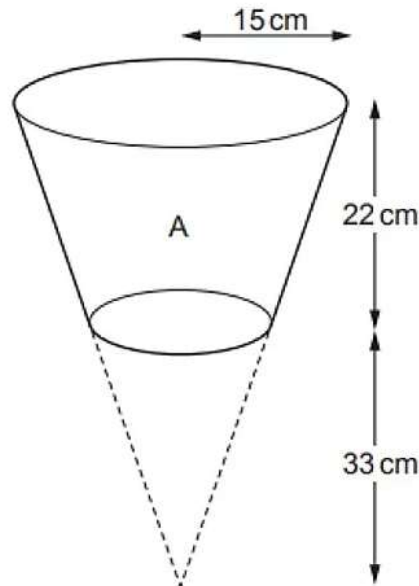

Diagram not drawn to scale

- the radius of the base of the bucket is 9 cm,
- the volume of the bucket is $3234\pi \text{ cm}^3$.

Bucket B is shown below. It is mathematically similar to Bucket A.

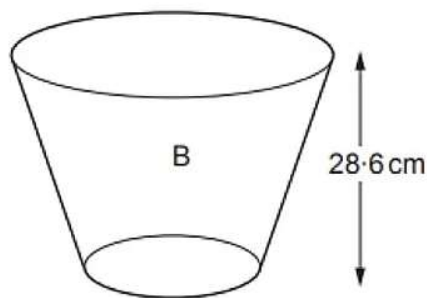

Diagram not drawn to scale

Calculate the number of **gallons** Bucket B can hold when full.

[6]

Remember: 1 gallon = 8 pints

Higher Maths Nov 2019 P2 Q11b

- (b) A rhombus has an area of 36.8 cm^2 .
The rhombus is enlarged by a scale factor of 7.
Calculate the area of the enlarged rhombus.

[2]

Higher Maths Sample 2 P1 Q11

11. A metal bar can be melted down to form 875 solid ornaments of height 6.3 cm .
How many similar ornaments of height 31.5 cm could have been formed from the same metal bar?

[4]

Higher Numeracy Sample 2 P1 Q10

10. Greta has 50 empty jelly moulds which she plans to fill with layers of red and green jelly. Each jelly mould is shaped as an inverted hollow cone of height 15 cm and volume 540 cm^3 .

Greta begins by making 1 litre of red jelly. She then pours an equal amount into each of the 50 jelly moulds.

Calculate the height of the red jelly in each jelly mould.
You must show all your working.

[6]

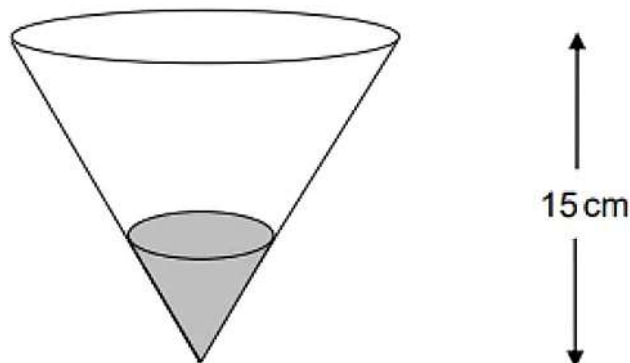

Diagram not drawn to scale

(c) Alun has 5 identical metal cylinders, each of length 40 mm.

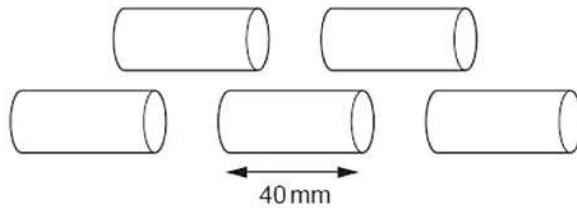

Diagram not drawn to scale

He has been asked to make a solid sphere of radius 30 mm.

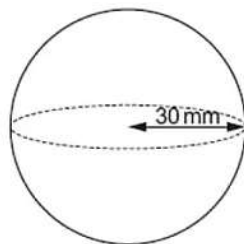

Diagram not drawn to scale

He melts the 5 cylinders and recasts all the metal to make the sphere.

Calculate the radius of each of the cylinders.

Give your answer in mm, in the form $a\sqrt{b}$, where a and b are integers, and b is as small as possible. [6]

Higher Numeracy Summer 2018 P1 Q12

Ffiol-Aur is a company that makes vases.

They make one of their vases in two mathematically similar sizes.

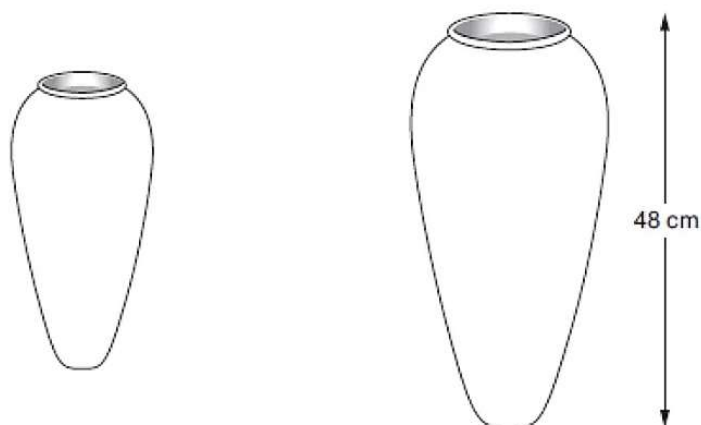

Diagrams not drawn to scale

A decorative glaze covers the surfaces of each vase.
The glaze covers an area of:

- 400 cm^2 on the smaller vase,
- 3600 cm^2 on the larger vase.

The height of the larger vase is 48 cm.
Calculate the height of the smaller vase.

[3]

Higher Maths Nov 2017 P2 Q15

Two **similar** pyramids have volumes of 3970 cm^3 and 3100 cm^3 respectively.
The height of the larger pyramid is 25 cm.
Calculate the height of the smaller pyramid.

[3]

Higher Maths Nov 2016 P2 Q17

Two similar shapes have areas of 700 cm^2 and 140 cm^2 .
The perimeter of the smaller shape is 83 cm.
Calculate the perimeter of the larger shape.

[3]

Higher Maths Summer 2019 P2 Q20

Two **similar** solids have base areas of 47 cm^2 and 199 cm^2 , as shown below.
The volume of the smaller solid is 350 cm^3 .

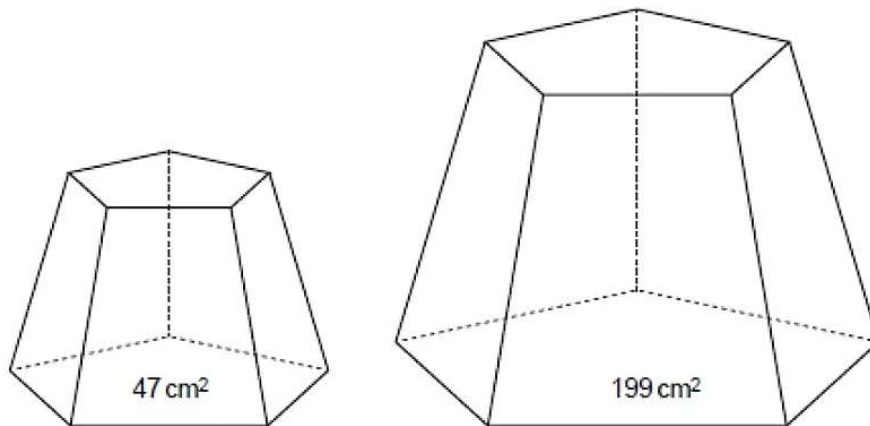

Diagram not drawn to scale

Calculate the volume of the larger solid.

[4]

The front views of two mathematically similar milk cartons are shown below.



Diagram not drawn to scale

- (a) Circle either TRUE or FALSE for each statement given below. [1]

STATEMENT		
The ratio of the lengths of the cartons is the same as the ratio of the heights of the cartons.	TRUE	FALSE
The ratio of the volumes of the cartons is the same as the ratio of the heights of the cartons.	TRUE	FALSE

- (b) It is claimed that the larger carton contains double the amount of milk contained in the smaller carton. Show that this claim is not true. Explain your answer. [3]
- (c) Another similar milk carton has a label with an area that is one quarter of the area of the label on the carton of height 24 cm.



Diagram not drawn to scale

Calculate the height of this new carton. [3]